

Flexi-Coat[®]

Technical Data Sheet

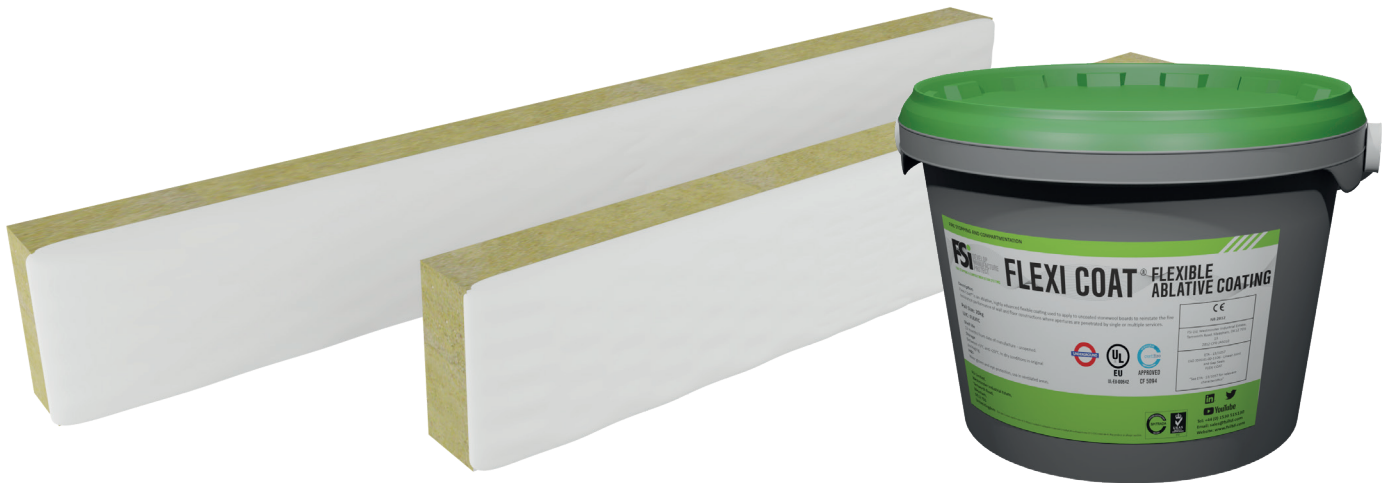

UAE Certificate of
Compliance



APPROVED
CF5094



ETA 13-1057
ETA 15-0434
CE-2812-CPR-JA5010



00642

FSi Limited
Westminster Industrial Estate
Tamworth Road
Measham
DE12 7DS
UK



www.fsilttd.com
Email: technical@fsilttd.com
Tel: +44 (0) 1530 515130
Fax: +44 (0) 1530 273564

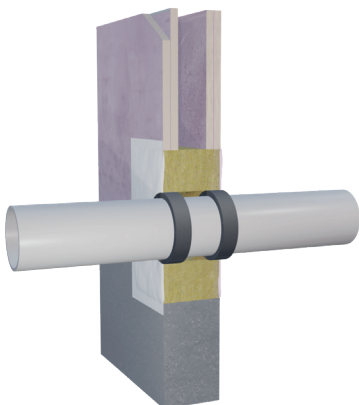
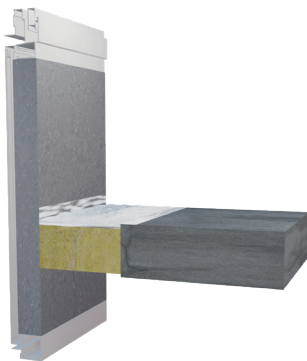
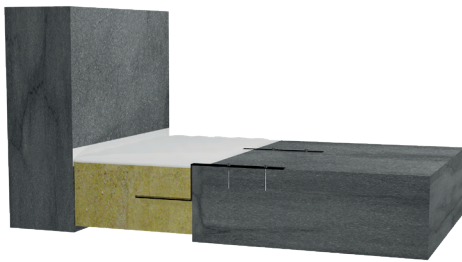

Flexi-Coat® is a highly advanced flexible penetration and aperture sealing system. The Flexi-Coat® is supplied in the form of both completed pre-coated Flexi-Coat® Fingers and as a coating to be applied to stone/mineral wool backing material. Flexi-Coat® has also been tested in accordance with **EN1364-4** and is third party certified.

Intended areas of use

- To reinstate fire resistance through walls and floors
- Movement seals in linear joints and penetration seals
- Multi-service penetrations
- Ideal for slab edge and head of wall applications
- Fire stop for internal apertures
- Curtain wall and perimeter facades

Key product advantages

- Causes no known effects to plastic, cables or metal
- Highly flexible and water resistant
- Halogen free, resists fungi and vermin
- Dry fit system depending on application
- Can be brush, trowel or spray applied
- Prevention of air leakage
- Provides cold smoke seal
- Excellent acoustic performance

Product Specification

Product Description	
Colour	White (others on request)
Cure Rate	0.5mm per day at 50% relative humidity @ 23°C
Tack Free	6hrs at 23°C, 50% RH
Coating Thickness	2.5mm nominal, wet coating thickness
Coverage	2.8kg/m ² , 2.24L/m ²
Classification	EN 13501-2, EN 13501-1
Product Size	10Kg, 20Kg, 1200 x 150 x 100mm fingers
Movement	+/- 25%
Shelf Life	18 months for wet product

Test Data

Test Description	Result	Test Standard
Specific Gravity (coating)	1.2 - 1.35g/cm ³	ISO 2811-1:2011
Fire Resistance	Up to EI 120	EN 13501-2, EN 1366-3, EN 1366-4, EN1364-4
Reaction to fire	B-s1, d0	EN 13501-1
Acoustic	Up to 49dB	EN ISO 10140-2:2010
Air Permeability	600 Pa EN 1026 - 100Pa 0.4/1.5 m ³ /h/m ²	EN1026
Water Permeability	450 Pa - No Leakage	EN 1027
VOC % Non-aqueous volatiles (105°C)	11	LEED

FSi has Technical Representatives who provide assistance in the selection and specification of FSi products. For more information, specification and technical advice please call our Head Office on Tel: +44 (0) 1530 515130. Guarantee / Warranty: FSi products are manufactured to rigid standards of quality. No liability can be accepted for the information provided in this document although it is published in good faith and believed to be correct. FSi Limited reserves the right to alter product specifications without prior notice, in line with our Company policy of continuous development and improvement.

Product Information

Substrates

Walls shall be a minimum of 100mm thick. Substrates shall be classified in accordance with EN13501-2 to the required fire resistance period. Masonry / Concrete walls shall have a minimum density for concrete or brick of 780kg/m³ and for aerated concrete blocks of 600kg/m³. All substrates shall have at least the same fire resistance as that required for the sealing system.

Service support requirements

Services should be rigidly supported via steel angles, hangers or channels, not further than 250mm from the surface of the sealing system on both faces of wall and top face of floor unless specified otherwise in the performance data.

Classification Terminology

Fire resistance classes are: E = Integrity, the product can withstand the fire from the non-fire side, I = Insulation, the product can withstand the temperature travelling down the service. Uncapped inside and outside the furnace, U/C = Uncapped inside and Capped outside the furnace, C/U = Capped inside and Uncapped outside the furnace.

Pre-Installation

Ensure that the aperture and services in question are tested with Flexi-Coat® system, and the site conditions are within the application specification. For combustible services when PyroPro HPE® is used, a sufficient annular space needs to be present around the service to apply sufficient installation depth. All services and apertures need to be clean and clear of all dust and loose particles. The aperture temperature needs to be at 5°C or above at time of installation. The Flexi-Coat® system must be in the orientation that ensure the lamellas are positioned to allow for compression. For Flexi-Coat® installation, stone wool backing material must be manufactured in accordance with EN 13162: 2001.

FLEXIBLE FIRE STOP FOR CURTAIN WALLING / FACADE

Products

- 1 - Flexi-Coat®
- 2 - Stone wool $\geq 80 \text{ kg/m}^3$, 100mm depth
or
- 1 & 2 - Flexi-Coat® Fingers

Classification

EI120

Supporting Construction

Rigid Floors (as per UL-EU-00642-CPR)

Maximum Joint Width (mm)	Standard
225	EN1364-4
350	EN1366-4

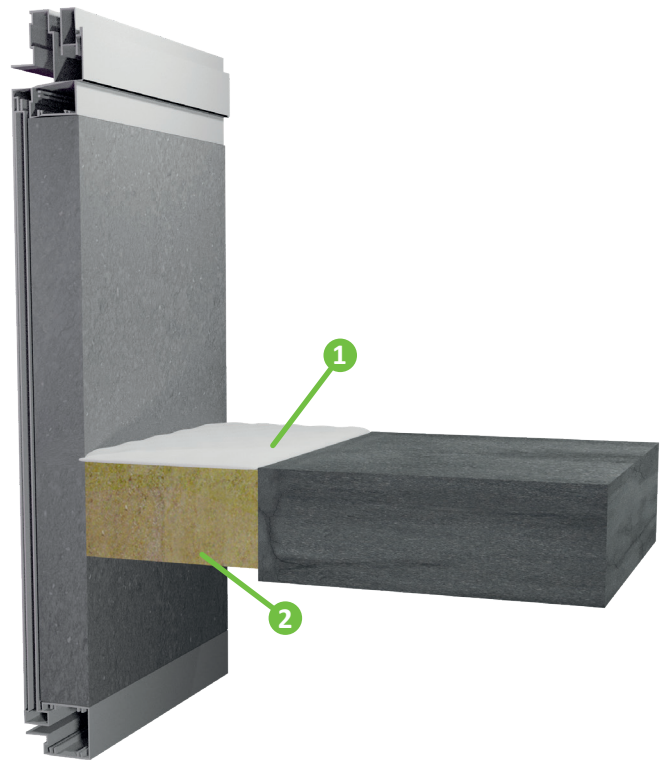

Installation Flexi-Coat® Finger:

Install Flexi-Coat® Finger into the opening flush with the upper surface of the floor with a minimum 20% compression fit between the substrates. Once the Flexi-Coat® Finger is installed, overcoat with Flexi-Coat® to abutting joints.

Installation Flexi-Coat®:

Install min. 100mm depth of stone wool (minimum 80kg/m^3) with a minimum 20% compression fit between the substrates effectively flush with the upper surface of the floor. Brush or trowel over the stone wool with Flexi-Coat®. Ensure Flexi-Coat® is applied to a **minimum DFT (dry film thickness) of 1mm which will require minimum 2.5mm WFT (wet film thickness)**

FLEXIBLE BARRIER IN RIGID FLOOR

Products

- 1 - Flexi-Coat®
- 2 - Stone wool $\geq 80 \text{ kg/m}^3$, 100mm depth
or
- 1 & 2 - Pre-coated Flexi-Coat® Fingers

Classification

Up to EI180

Supporting Construction

Rigid Floors (as per UL-EU-00642-CPR)

Maximum Joint Width (mm) Classification

Maximum Joint Width (mm)	Classification
200	E240 EI180
300	EI120

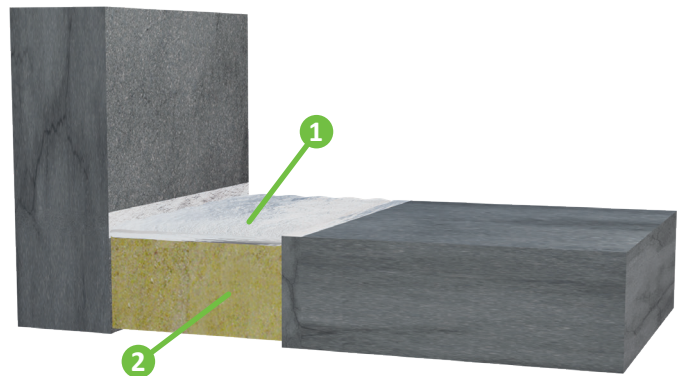

Installation Flexi-Coat® Finger:

Install Flexi-Coat® Finger into the opening flush with the upper surface of the floor with a minimum 20% compression fit between the substrates. Once the Flexi-Coat® Finger is installed, overcoat with Flexi-Coat® to abutting joints ensuring a minimum 20mm overlap on to all surrounding substrates.

Installation Flexi-Coat®:

Install min. 100mm depth of stone wool (minimum 80kg/m^3) with a minimum 20% compression fit between the substrates effectively flush with the upper surface of the floor. Brush or trowel over the stone wool with Flexi-Coat®. Ensure Flexi-Coat® is applied to a **minimum DFT (dry film thickness) of 1mm which will require minimum 2.5mm WFT (wet film thickness)** ensuring a minimum 20mm overlap on to all surrounding substrates.

FLEXIBLE BARRIER IN RIGID FLOOR

Products

- 1 - Flexi-Coat®
- 2 - Stone wool $\geq 80 \text{ kg/m}^3$, 100mm depth
or
- 1 & 2 - Flexi-Coat® Fingers

Classification

EI120

Supporting Construction

Rigid Floors (as per UL-EU-00642-CPR)

Maximum Joint Width (mm)

375

Support Fixings

*Fixing – 1.5mm thick steel Z type angle brackets installed mid depth of the Flexi-Coat® system to provide support. The brackets are to be mechanically fixed to the substrate with a suitable fire resistant anchor.

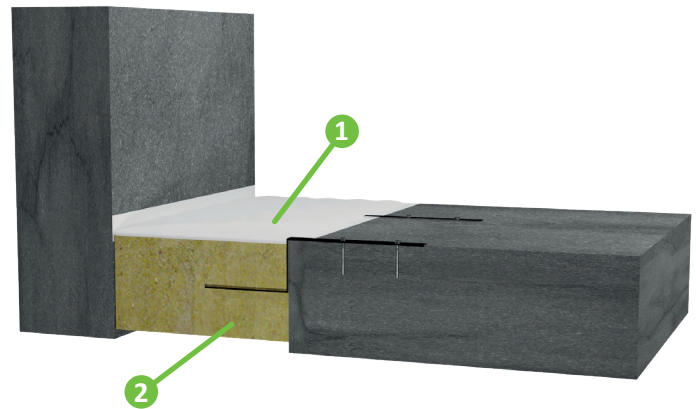

Installation Flexi-Coat® Finger:

Install Flexi-Coat® Finger into the opening flush with the upper surface of the floor with a minimum 20% compression fit between the substrates. Once the Flexi-Coat® Finger is installed, overcoat with Flexi-Coat® to abutting joints ensuring a minimum 20mm overlap on to all surrounding substrates..

Installation Flexi-Coat®:

Install min. 100mm depth of stone wool (minimum 80kg/m^3) with a minimum 20% compression fit between the substrates effectively flush with the upper surface of the floor. Brush or trowel over the stone wool with Flexi-Coat®. Ensure Flexi-Coat® is applied to a **minimum DFT (dry film thickness) of 1mm which will require minimum 2.5mm WFT (wet film thickness)** ensuring a minimum 20mm overlap on to all surrounding substrates.

FLEXIBLE BARRIER IN FLEXIBLE AND RIGID WALL

Products

- 1 - Flexi-Coat®
- 2 - Stone wool $\geq 80 \text{ kg/m}^3$, 100mm depth
or
- 1 & 2 - Flexi-Coat® Fingers
- 3 - 40kg/m³ 40mm thick stone wool,
200mm length (L/I)

Classification

Up to EI120

Supporting Construction

Flexible Wall: $\geq 100\text{mm}$,
Rigid Wall: $\geq 100\text{mm}$

Maximum Opening Size

730mm x 1200mm

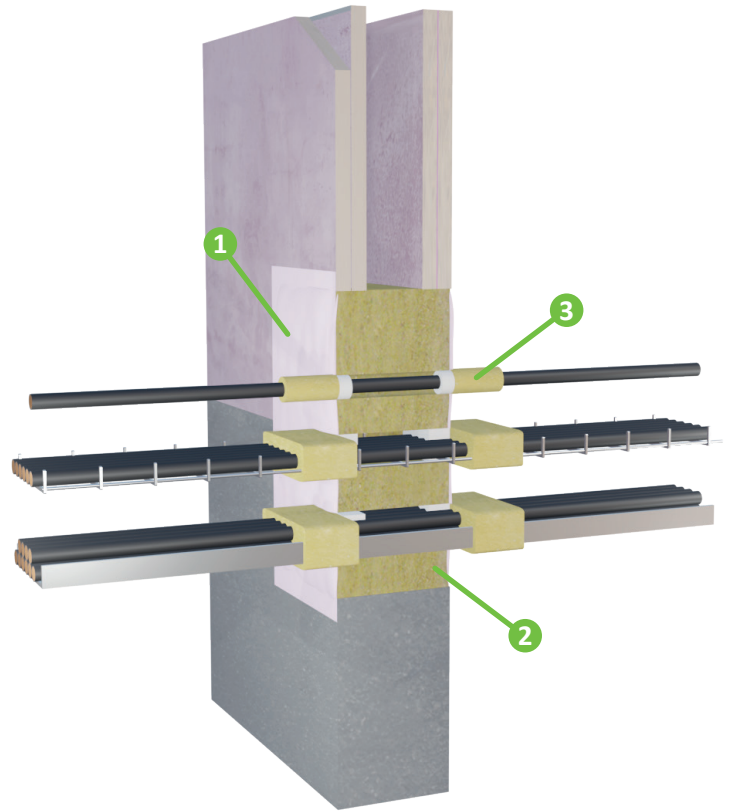

Penetration Specification	Classification
Electrical cable up to 21 - 50mm dia	EI90
Electrical cables 51mm - 80mm dia	E90 EI60
Cable trays and ladders	EI90
100mm diameter bundle telecommunication cable type 'F'	EI120
Unsheathed electrical cables up to 24mm dia	E90 EI60
Steel and Copper Conduits up to 16mm	EI90

Installation Flexi-Coat® Finger:

Install Flexi-Coat® Finger into the opening with a minimum 20% compression fit between the substrates and tightly packed around services. Once the Flexi-Coat® Finger is installed, overcoat with Flexi-Coat® to all joints/junctions ensuring a minimum 20mm overlap on to all surrounding substrates and services.

Installation Flexi-Coat®:

If supplied in liquid form the Flexi-Coat® is trowelled or sprayed into the aperture in or between the separating element/elements to a specified depth utilising stone wool backing material. Upon installation make sure that you install min. 100mm depth of stone wool (minimum 80kg/m^3) with a minimum 20% compression fit between the substrate and or around all services effectively, brush or trowel over the stone wool with Flexi-Coat®. Ensure Flexi-Coat® is applied to a minimum DFT (dry film thickness) of 1mm which will require minimum 2.5mm WFT (wet film thickness) with a minimum 20mm overlap on to all surrounding substrates/services.

FLEXIBLE BARRIER IN FLEXIBLE AND RIGID WALL

Products
1 - Flexi-Coat®
2 - Stone wool $\geq 80 \text{ kg/m}^3$, 100mm depth or
1 & 2 - Flexi-Coat® Fingers

Classification
Up to EI60

Supporting Construction
Flexible Wall: $\geq 100\text{mm}$, insulated Rigid Wall: $\geq 100\text{mm}$

Maximum Opening Size
730mm x 1200mm

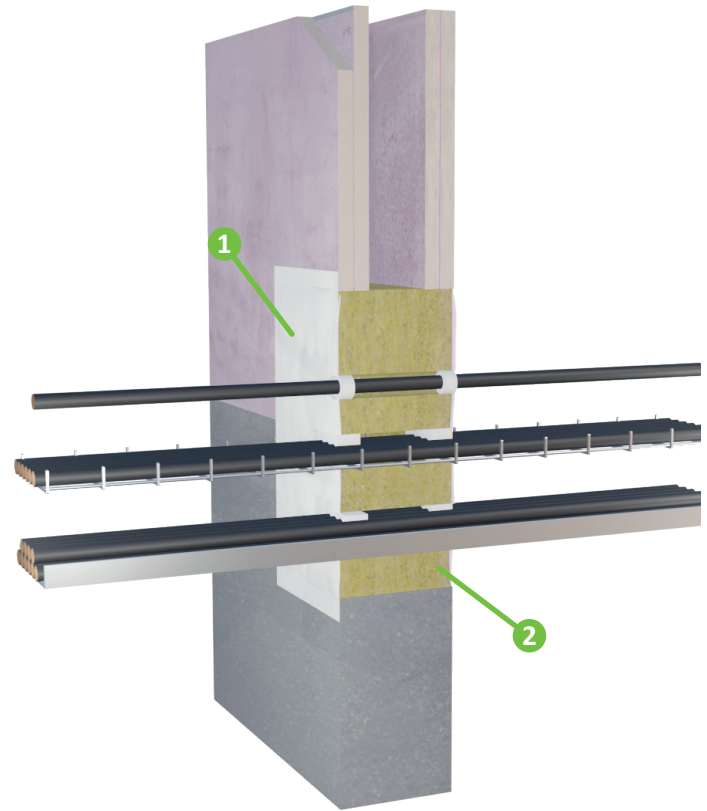

Penetration Specification	Classification
Electrical cable up to 21mm dia	EI60
Electrical cables 21mm - 80mm dia	E60 EI45
Cable trays and ladders	E60 EI30
100mm diameter bundle telecommunication cable type 'F'	EI60
Unsheathed electrical cables up to 24mm dia	E60 EI45
Steel and Copper Conduits up to 16mm	E60 EI30

Installation Flexi-Coat® Finger:
Install Flexi-Coat® Finger into the opening with a minimum 20% compression fit between the substrates and tightly packed around services. Once the Flexi-Coat® Finger is installed, overcoat with Flexi-Coat® to all joints/junctions ensuring a minimum 20mm overlap on to all surrounding substrates and services.

Installation Flexi-Coat®:
If supplied in liquid form the Flexi-Coat® is trowelled or sprayed into the aperture in or between the separating element/elements to a specified depth utilising stone wool backing material. Upon installation make sure that you install min. 100mm depth of stone wool (minimum 80kg/m^3) with a minimum 20% compression fit between the substrate and or around all services effectively, brush or trowel over the stone wool with Flexi-Coat®. Ensure Flexi-Coat® is applied to a minimum DFT (dry film thickness) of 1mm which will require minimum 2.5mm WFT (wet film thickness) with a minimum 20mm overlap on to all surrounding substrates/services.

FLEXIBLE BARRIER IN FLEXIBLE AND RIGID WALL

Products

- 1 - Flexi-Coat®
- 2 - Stone wool $\geq 80 \text{ kg/m}^3$, 100mm depth
or
- 1 & 2 - Flexi-Coat® Fingers
- 3 - PyroPro HPE® Sealant
- 4 - Elastomeric Insulation (CS)

Classification

E60, EI30 U/C, C/U, C/C

Supporting Construction

Flexible Wall: $\geq 100\text{mm}$,
Rigid Wall: $\geq 100\text{mm}$

Maximum Opening Size

730mm x 1200mm

Penetration Service Type	Pipe Diameters (mm)
--------------------------	---------------------

Steel / Copper insulated with elastomeric insulation 20mm thick (S/C)	≤ 159
---	------------

Additional Installation

15mm deep x 10mm wide annulus of PyroPro HPE® to both faces around the penetration service

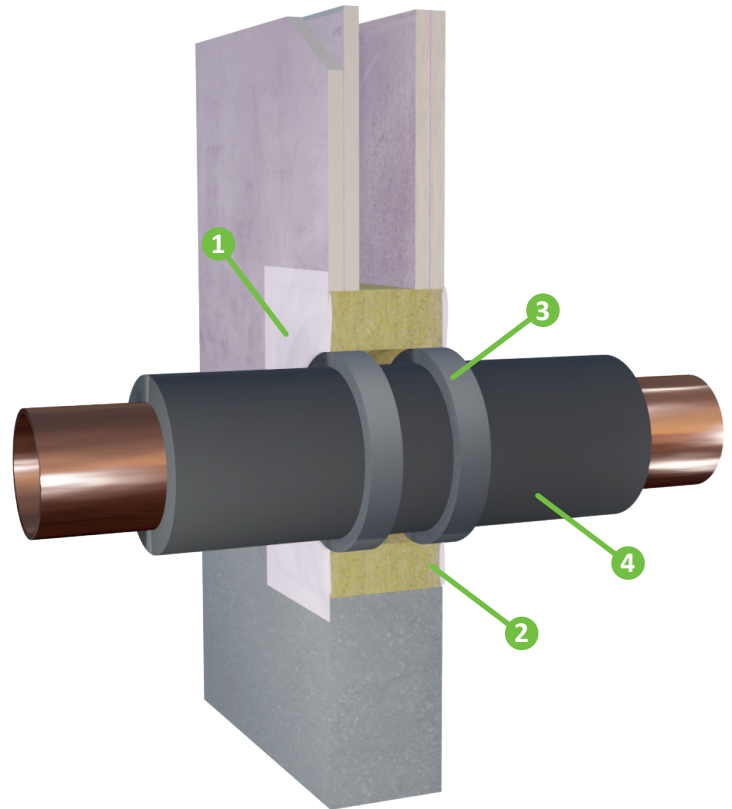

Installation Flexi-Coat® Finger:

Install Flexi-Coat® Finger into the opening with a minimum 20% compression fit between the substrates and tightly packed around services. Once the Flexi-Coat® Finger is installed, overcoat with Flexi-Coat® to all joints/junctions ensuring a minimum 20mm overlap on to all surrounding substrates and services.

Installation Flexi-Coat®:

If supplied in liquid form the Flexi-Coat® is trowelled or sprayed into the aperture in or between the separating element/elements to a specified depth utilising stone wool backing material. Upon installation make sure that you install min. 100mm depth of stone wool (minimum 80kg/m^3) with a minimum 20% compression fit between the substrate and or around all services effectively, brush or trowel over the stone wool with Flexi-Coat®. Ensure Flexi-Coat® is applied to a minimum DFT (dry film thickness) of 1mm which will require minimum 2.5mm WFT (wet film thickness) with a minimum 20mm overlap on to all surrounding substrates/services.

FLEXIBLE BARRIER IN FLEXIBLE AND RIGID WALL

Products
1 - Flexi-Coat®
2 - Stone wool ≥ 80 kg/m ³ , 100mm depth or
1 & 2 - Flexi-Coat® Fingers

Classification
E60 U/C, C/U, C/C

Supporting Construction
Flexible Wall: ≥100mm, Rigid Wall: ≥100mm

Maximum Opening Size
1200mm x 1200mm

Penetration Service Type	Pipe Diameters (mm)
Steel / Copper	≤ 159

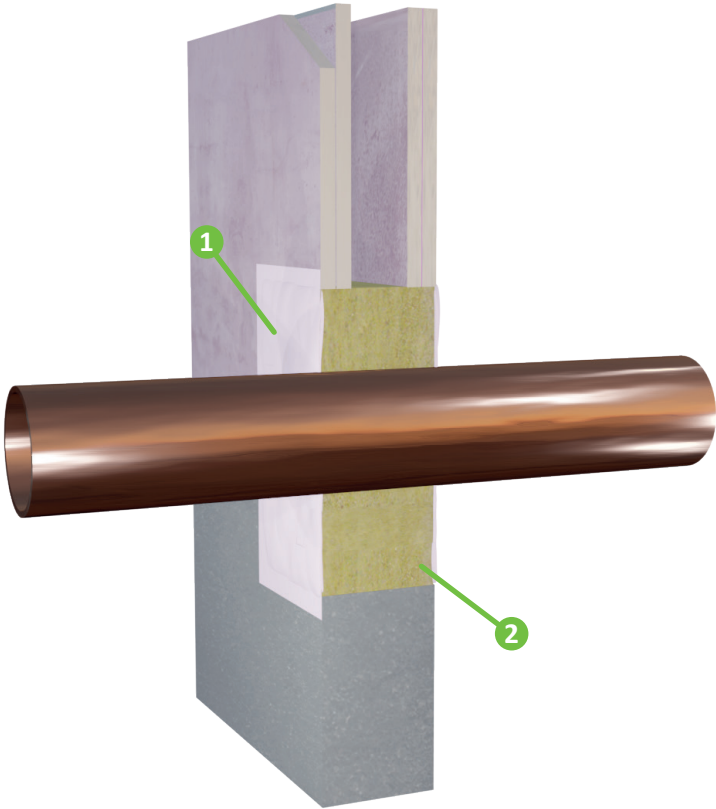

Installation Flexi-Coat® Finger:
 Install Flexi-Coat® Finger into the opening with a minimum 20% compression fit between the substrates and tightly packed around services. Once the Flexi-Coat® Finger is installed, overcoat with Flexi-Coat® to all joints/junctions ensuring a minimum 20mm overlap on to all surrounding substrates and services.

Installation Flexi-Coat®:
 If supplied in liquid form the Flexi-Coat® is trowelled or sprayed into the aperture in or between the separating element/elements to a specified depth utilising stone wool backing material. Upon installation make sure that you install min. 100mm depth of stone wool (minimum 80kg/m³) with a minimum 20% compression fit between the substrate and or around all services effectively, brush or trowel over the stone wool with Flexi-Coat®. Ensure Flexi-Coat® is applied to a minimum DFT (dry film thickness) of 1mm which will require minimum 2.5mm WFT (wet film thickness) with a minimum 20mm overlap on to all surrounding substrates/services.

FLEXIBLE BARRIER IN FLEXIBLE AND RIGID WALL

Products

- 1 - Flexi-Coat®
- 2 - Stone wool $\geq 80 \text{ kg/m}^3$, 100mm depth
or
- 1 & 2 - Flexi-Coat® Fingers
- 3 - PyroPro HPE® Sealant

Classification

E160 U/C, C/C

Supporting Construction

Flexible Wall: $\geq 100\text{mm}$,
Rigid Wall: $\geq 100\text{mm}$

Maximum Opening Size

1200mm x 1200mm

Penetration Service Type	Pipe Diameters (mm)
--------------------------	---------------------

PVC-U

Max. 200

Additional Installation

25mm deep x 20mm wide annulus of PyroPro HPE® to both faces of the wall around the penetration service

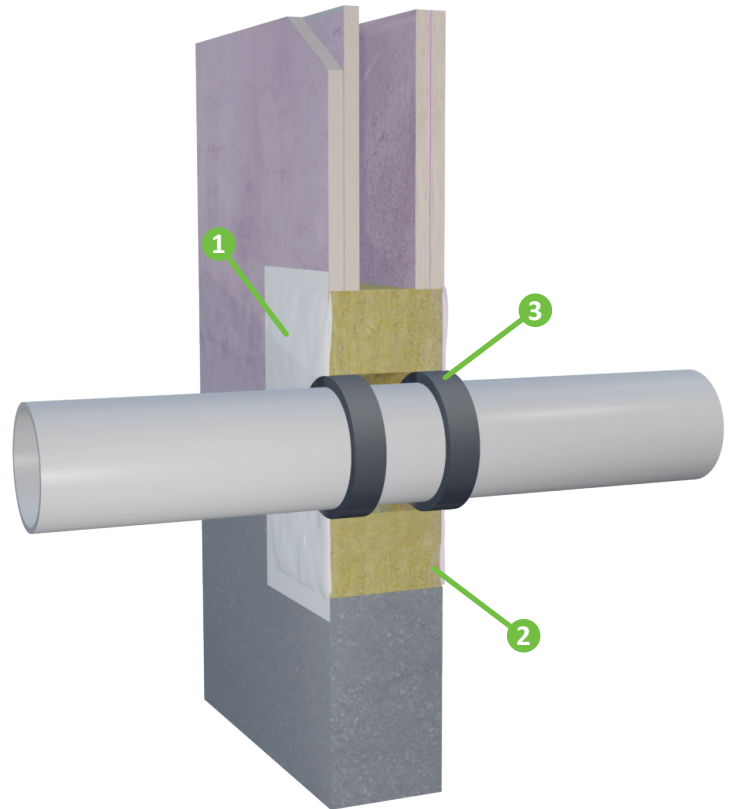

Installation Flexi-Coat® Finger:

Install Flexi-Coat® Finger into the opening with a minimum 20% compression fit between the substrates and tightly packed around services. Once the Flexi-Coat® Finger is installed, overcoat with Flexi-Coat® to all joints/junctions ensuring a minimum 20mm overlap on to all surrounding substrates and services.

Installation Flexi-Coat®:

If supplied in liquid form the Flexi-Coat® is trowelled or sprayed into the aperture in or between the separating element/elements to a specified depth utilising stone wool backing material. Upon installation make sure that you install min. 100mm depth of stone wool (minimum 80kg/m^3) with a minimum 20% compression fit between the substrate and or around all services effectively, brush or trowel over the stone wool with Flexi-Coat®. Ensure Flexi-Coat® is applied to a minimum DFT (dry film thickness) of 1mm which will require minimum 2.5mm WFT (wet film thickness) with a minimum 20mm overlap on to all surrounding substrates/services.

FLEXIBLE BARRIER IN RIGID WALL

Products

- 1 - Flexi-Coat®
- 2 - Stone wool $\geq 80 \text{ kg/m}^3$, 100mm depth
or
- 1 & 2 - Flexi-Coat® Fingers
- 3 - 40kg/m³ 40mm thick stone wool,
200mm length (L/l)

Classification

Up to EI120

Supporting Construction

Rigid Wall: $\geq 150\text{mm}$

Maximum Opening Size

900mm x 900mm

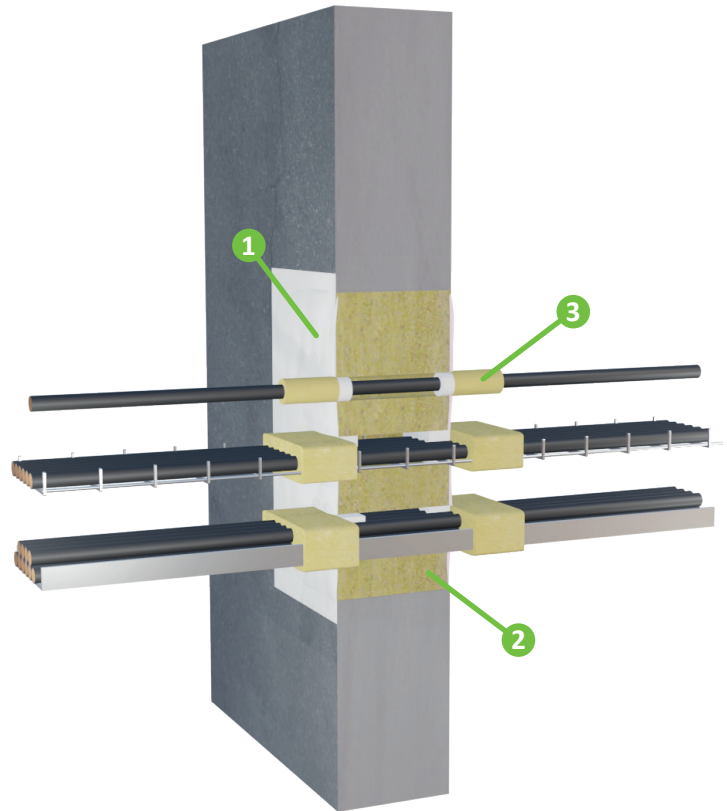

Penetration Specification	Classification
Electrical cable up to 21mm dia	EI120
Electrical cable 22 - 50mm dia	E90 EI60
Electrical cables 51mm - 80mm dia	EI60
Cable trays and ladders	EI60
100mm diameter bundle telecommunication cable type 'F'	EI120
Unsheathed electrical cables up to 24mm dia	EI120
Steel and Copper Conduits up to 16mm	EI120

Installation Flexi-Coat® Finger:

Install Flexi-Coat® Finger into the opening with a minimum 20% compression fit between the substrates and tightly packed around services. Once the Flexi-Coat® Finger is installed, overcoat with Flexi-Coat® to all joints/junctions ensuring a minimum 20mm overlap on to all surrounding substrates and services.

Installation Flexi-Coat®:

If supplied in liquid form the Flexi-Coat® is trowelled or sprayed into the aperture in or between the separating element/elements to a specified depth utilising stone wool backing material. Upon installation make sure that you install min. 100mm depth of stone wool (minimum 80kg/m³) with a minimum 20% compression fit between the substrate and or around all services effectively, brush or trowel over the stone wool with Flexi-Coat®. Ensure Flexi-Coat® is applied to a minimum DFT (dry film thickness) of 1mm which will require minimum 2.5mm WFT (wet film thickness) with a minimum 20mm overlap on to all surrounding substrates/services.

FLEXIBLE BARRIER IN RIGID WALL

Products

- 1 - Flexi-Coat®
- 2 - Stone wool $\geq 80 \text{ kg/m}^3$, 100mm depth
or
- 1 & 2 - Flexi-Coat® Fingers
- 3 - 40kg/m³ 40mm thick stone wool,
200mm length (L/I)

Classification

Up to EI120 U/C, C/U, C/C

Supporting Construction

Rigid Wall: $\geq 150\text{mm}$

Maximum Opening Size

900mm x 900mm

Penetration Service Type	Classification
Mild steel 200mm dia. and 5 - 14.2mm wall	E90 EI30
Copper or mild steel pipe 40mm dia. and 1.5 - 14.2mm wall	E120 EI60
Copper/steel pipe 159mm dia. 2 - 14.2mm wall	EI120

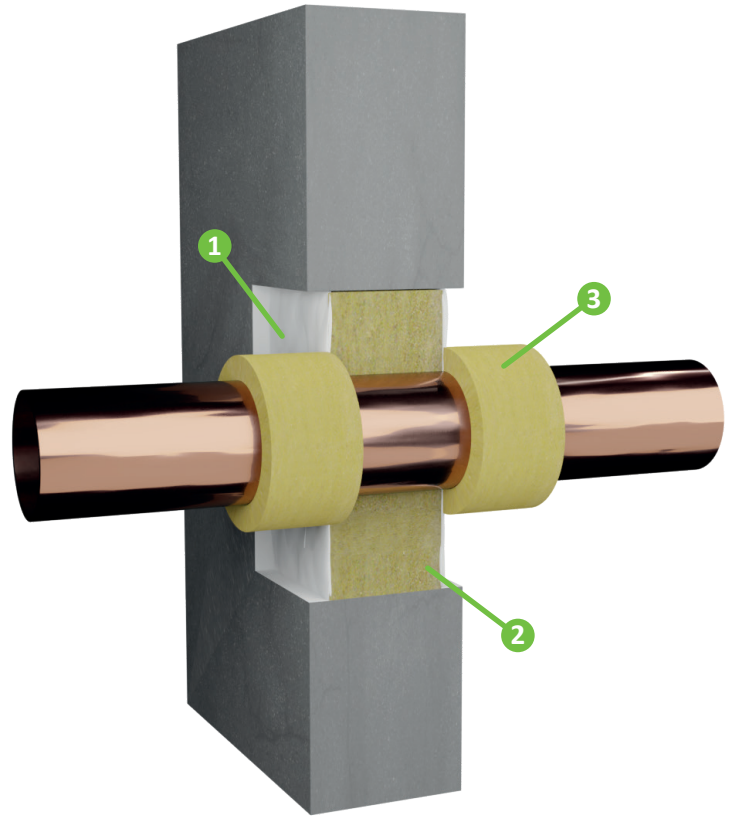

Installation Flexi-Coat® Finger:

Install Flexi-Coat® Finger into the opening with a minimum 20% compression fit between the substrates and tightly packed around services. Once the Flexi-Coat® Finger is installed, overcoat with Flexi-Coat® to all joints/junctions ensuring a minimum 20mm overlap on to all surrounding substrates and services.

Installation Flexi-Coat®:

If supplied in liquid form the Flexi-Coat® is trowelled or sprayed into the aperture in or between the separating element/elements to a specified depth utilising stone wool backing material. Upon installation make sure that you install min. 100mm depth of stone wool (minimum 80kg/m³) with a minimum 20% compression fit between the substrate and or around all services effectively, brush or trowel over the stone wool with Flexi-Coat®. Ensure Flexi-Coat® is applied to a minimum DFT (dry film thickness) of 1mm which will require minimum 2.5mm WFT (wet film thickness) with a minimum 20mm overlap on to all surrounding substrates/services.

FLEXIBLE BARRIER AT HEAD OF WALL

Products

- 1 - Flexi-Coat®
- 2 - Stone wool $\geq 80 \text{ kg/m}^3$, 100mm depth
or
- 1 & 2 - Flexi-Coat® Fingers

Classification

Up to EI180

Supporting Construction

Floor & wall: Thickness $\geq 150\text{mm}$, aerated concrete, concrete or brickwork, density $\geq 670 \text{ kg/m}^3$

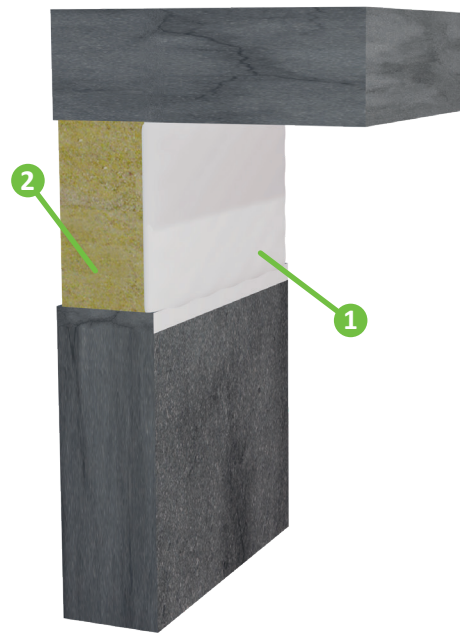

Maximum Joint Width (mm)	Classification
200	E240 EI180
300	EI120

Installation Flexi-Coat® Finger:

Install Flexi-Coat® Finger into the opening with a minimum 20% compression fit between the substrates. Once the Flexi-Coat® Finger is installed, overcoat with Flexi-Coat® to all joints/junctions ensuring a minimum 20mm overlap on to all surrounding substrates.

Installation Flexi-Coat®:

Install min. 100mm depth of stone wool (minimum 80kg/m^3) with a minimum 20% compression fit between the substrates effectively. Brush or trowel over the stone wool with Flexi-Coat®. Ensure Flex Coat® is applied to a **minimum DFT (dry film thickness) of 1mm which will require minimum 2.5mm WFT (wet film thickness)** with a minimum 20mm overlap on to all surrounding substrates.

FLEXIBLE BARRIER AT HEAD OF WALL

Products

- 1 - Flexi-Coat®
- 2 - Stone wool $\geq 80 \text{ kg/m}^3$, 100mm depth
or
- 1 & 2 - Flexi-Coat® Fingers

Classification

EI120

Supporting Construction

Floor: Thickness $\geq 150\text{mm}$, aerated concrete, concrete or brickwork, density $\geq 670 \text{ kg/m}^3$

Maximum Joint Width (mm)

375

Support Fixings

*Fixing – 1.5mm thick steel Z type angle brackets installed mid depth of the Flex-Coat® system to provide support. The brackets are to be mechanically fixed to the substrate with a suitable fire resistant anchor.

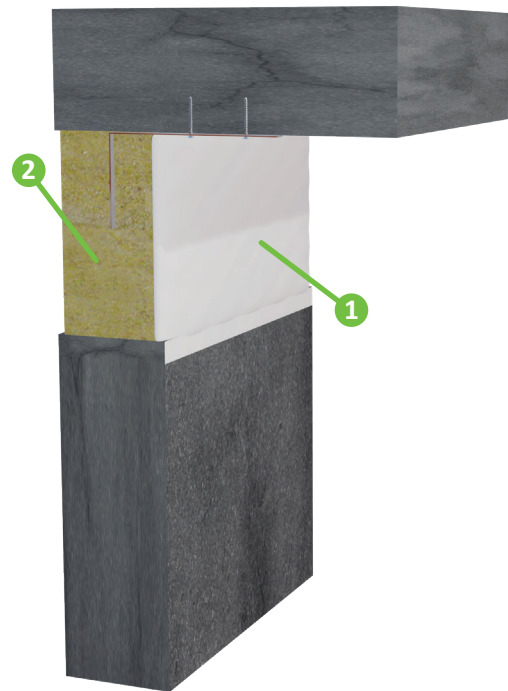

Installation Flexi-Coat® Finger:

Install Flexi-Coat® Finger into the opening with a minimum 20% compression fit between the substrates. Once the Flexi-Coat® Finger is installed, overcoat with Flexi-Coat® to all joints/junctions ensuring a minimum 20mm overlap on to all surrounding substrates.

Installation Flexi-Coat®:

Install min. 100mm depth of stone wool (minimum 80kg/m^3) with a minimum 20% compression fit between the substrates effectively. Brush or trowel over the stone wool with Flexi-Coat®. Ensure Flex Coat® is applied to a **minimum DFT (dry film thickness) of 1mm which will require minimum 2.5mm WFT (wet film thickness)** with a minimum 20mm overlap on to all surrounding substrates.